

REVISION RECORD

REV	DESCRIPTION	DATE	APPD

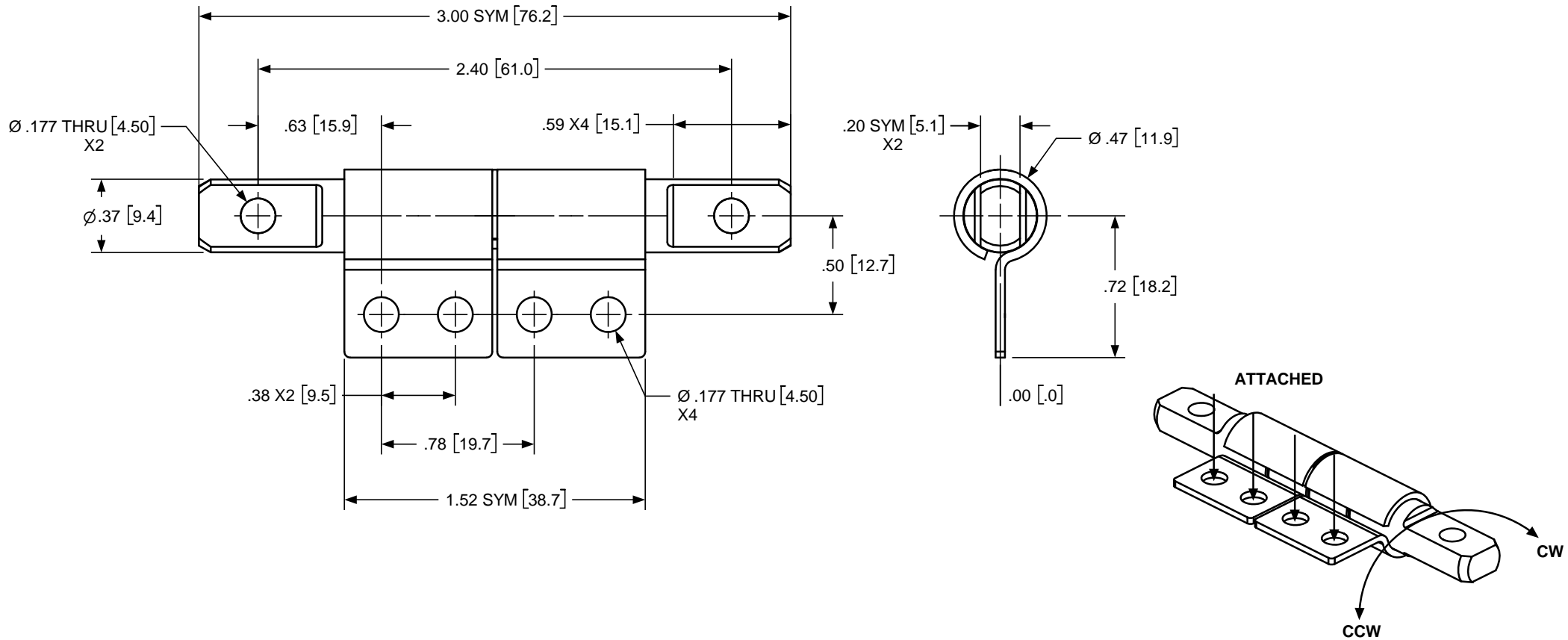

- NOTES:
- HINGE TORQUE: UNBALANCED.
  - CCW TORQUE = 40.0 ± 15% IN.LB [460.8 ± 15% KG.MM].
  - CW TORQUE IS LESS THAN CCW TORQUE.

<b>SHINELOT</b>		TITLE			
ALL INFORMATION ON THIS PRINT ARE PROPRIETARY TO SHINELOT, AND SHALL NOT BE USED IN WHOLE OR IN PART WITHOUT SHINELOT'S CONSENT.		<b>ENGLISH / METRIC TOLERANCES</b>		MATERIAL <b>STEEL BAND &amp; SHAFT</b>	
		<b>METRIC</b> .X ±.3 MM .XX ±.13 MM .XXX ±.005 MM	<b>ENGLISH</b> .XX ±015 IN .XXX ±005 IN .XXXX ±0002 IN	SIZE <b>B</b>	DWG NO <b>C8-010</b>
USED ON	REV	ANGLE ±1°		SCALE <b>2:1</b>	DATE
				SHEET <b>1</b> OF <b>1</b>	